

CSX

Extra Large Swing Capacity

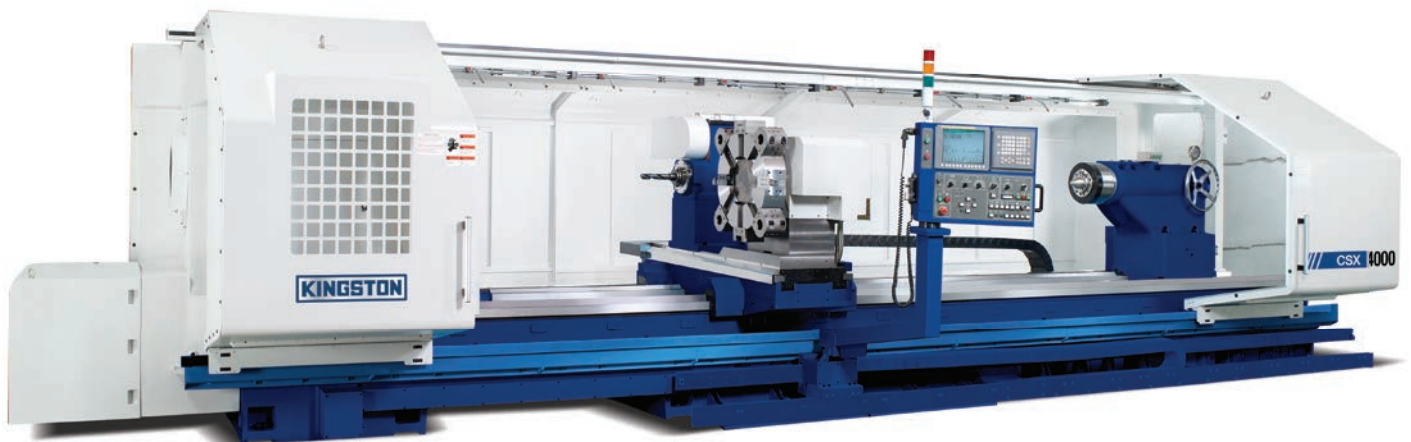

KINGSTON

CSX

Extra Large Swing Capacity

Kingston's CSX is the largest and brawniest entry in its heavy-duty lineup, boasting an impressive 59" swing (35.4" over cross slide) for your largest work pieces — and a colossal 1-meter (39.4") bed width for maximal stability during the heaviest cutting. Spindle bore sizes up to 14.7" and lengths to 240" between centers — plus a powerful 60 HP motor — mean this machine can tackle just about anything.

Machine Highlights

- 1 **Extra Large Swing Capacity** 59" Swing over Bed, 35.4" Swing over Cross slide
- 2 **Extra wide 39.4" 2 V-way Bed**
- 3 **Heavily Ribbed One-Piece Casting** for increased rigidity
- 4 **Boxway Cross Slide** on Carriage for heavy cutting
- 5 **V8 Turret with 2 1/2" Boring Bar holders.** Optional Rear Turret

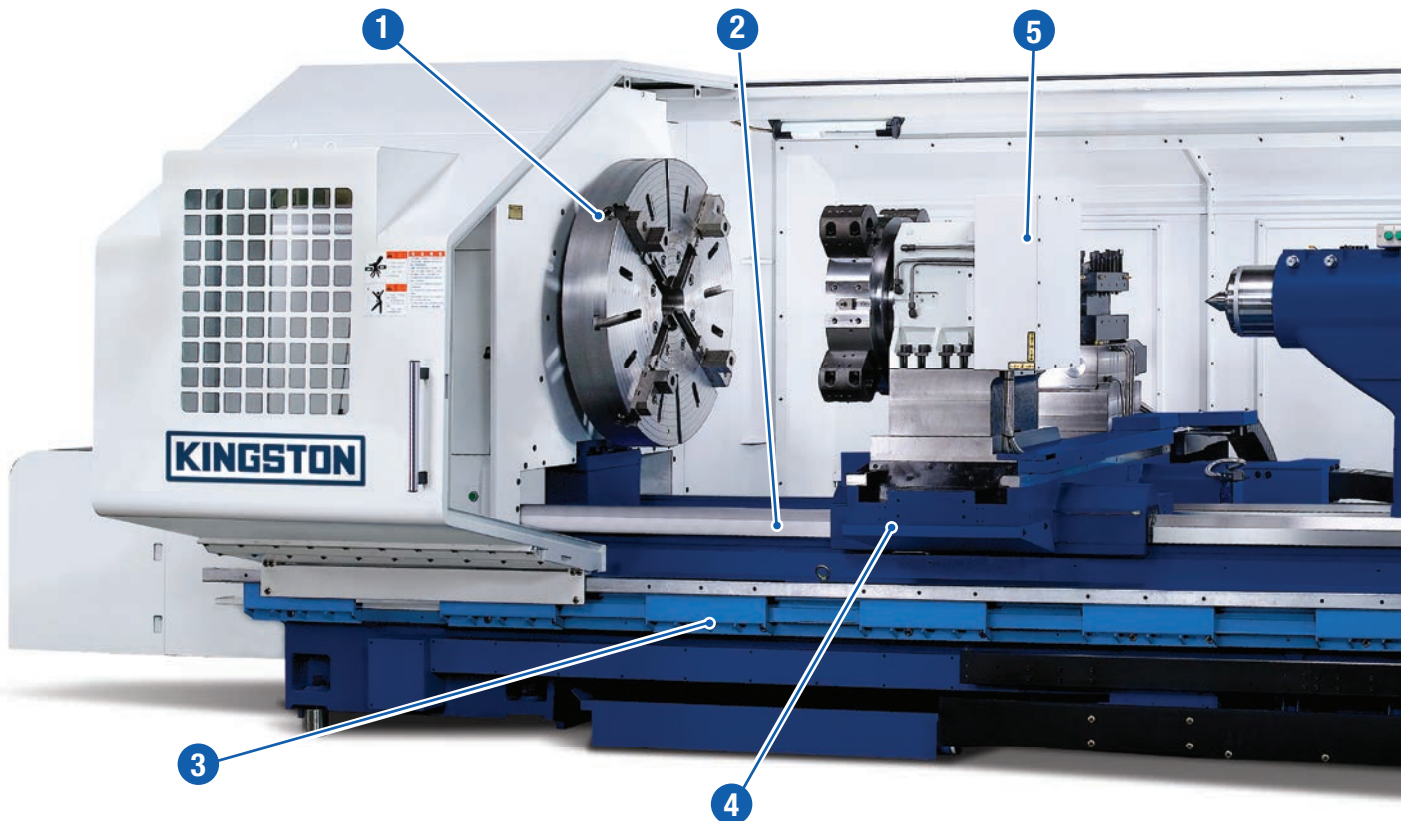
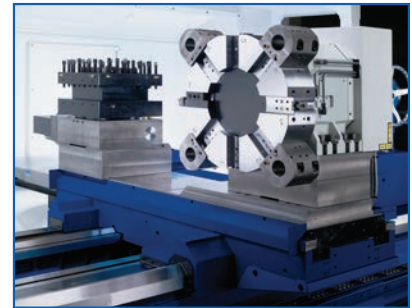

6

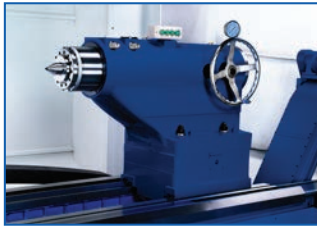

Powerful Heavy Duty Tailstock with built in center & A1-8 Nose to direct mount a chuck.

7

Center Chip Conveyor beneath bedway. Optional Rear and Front Chip Conveyors.

8



Optional Roller Bracket with two sleeves

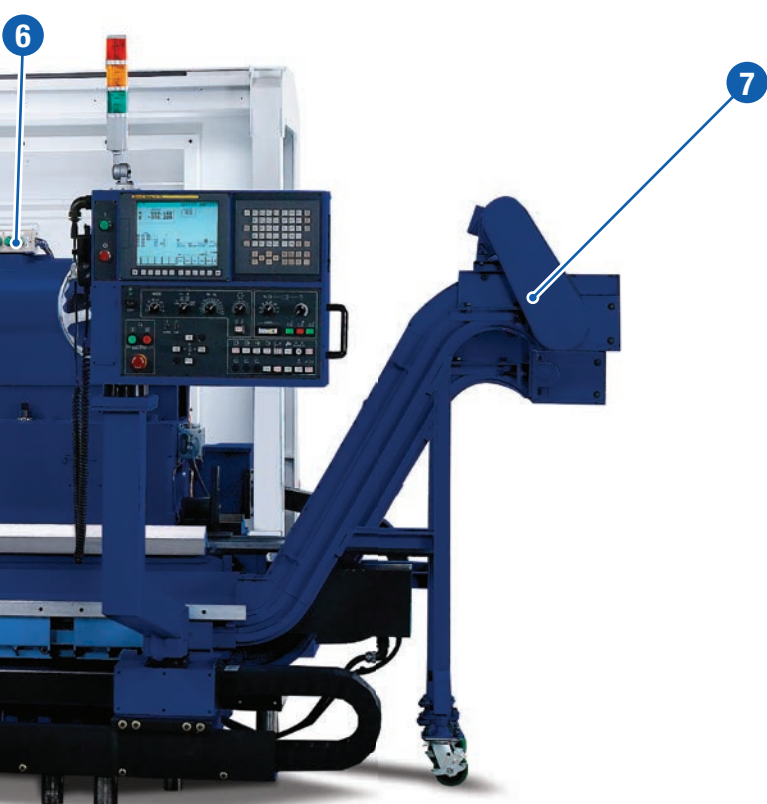

Standard Features

- Bore: 7.1", 10", 14.5"
- Swing: 59" Over Bed, 39.4" over Cross slide
- CC: 80" - 240"
- 50HP (cont) / 60HP (30 min)
- 39.4" Bed Width, One Piece Casting
- Box Way Cross Slide on Carriage
- V8 or H4 Hydraulic Turret
- Rear Chuck Adapter
- Center Chip Conveyor
- Tailstock with Built in Center, MT#6, Moves by Engaging with Carriage
- Full length Splash Guard
- Fanuc OiTF Controller with Manual Guide i

Optional Accessories

- V12 Live Tooling Turret
- 20.8" Bore option available upon request
- Additional H4 (350) or H6 Rear turret
- High Pressure Coolant Pump
- Steady Rest with Roller Jaw
- Roller Bracket with Two Sleeves
- 7" Boring Bar Support
- Front and Rear Chip Conveyors

CSX

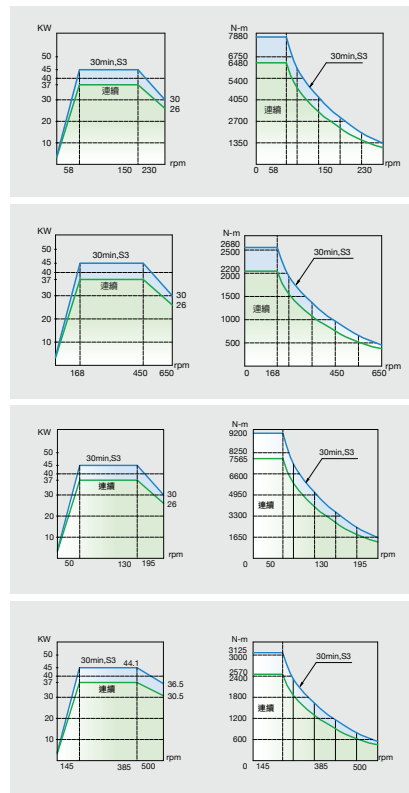

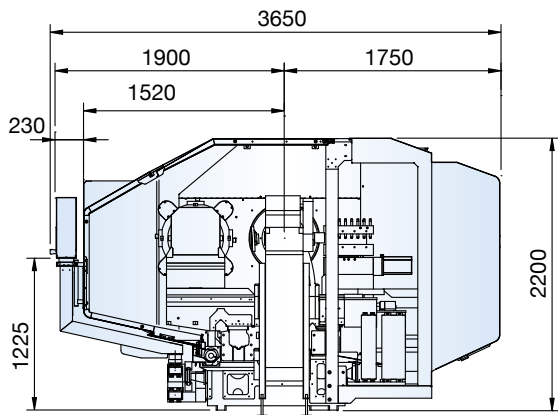
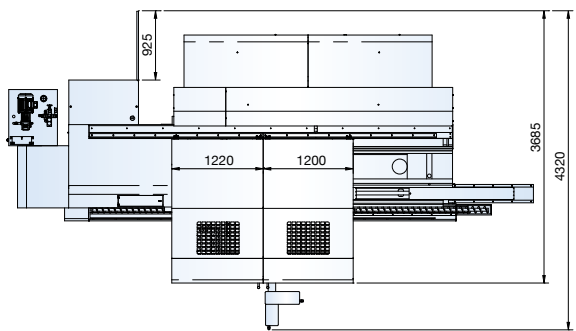
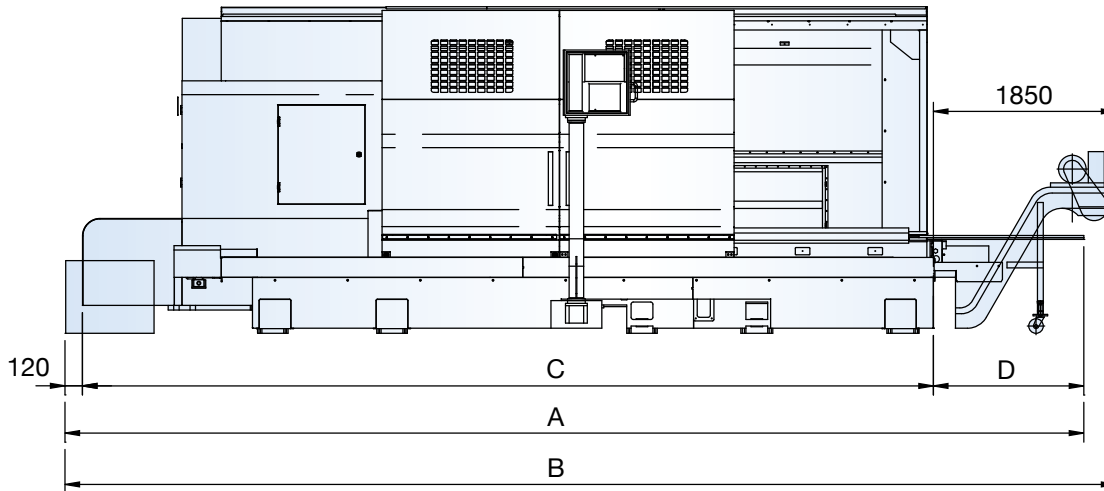

Kingston Machine Tool

5421 Business Dr.
 Huntington Beach, CA 92649
 (714) 894-1648 | Fax (714) 897-2616
 kingstonmachine.com



Capacity	CSX 7	CSX 10	CSX 14
Swing Over Bed		59"	
Swing Over Cross Slide		35.4"	
Maximum Cutting Diameter		47.2"	
Distance Between Centers	80" / 120" / 160" / 200" / 240"		
Maximum Cutting Length	79" / 118" / 158" / 197" / 237"		
Width of Bed		39.4"	
Headstock			
Spindle Bore	7.1"	10"	14.7"
Spindle Motor	50 HP / 60 HP (30min)		
Type of Spindle Nose	A2-15	A2-15	A2-20
Gear Box			
Number of Speed Ranges	2		
Spindle Speed (RPM)	6-650	6-650	4-500
Turret			
V8 Hydraulic (Std), H4 or H6 (Op)			
Traverse			
Max. Stroke X-Axis	28.9"		
Max. Stroke Z-Axis	82.5" / 121.8" / 161.2" / 200.6" / 240"		
Rapid Traverse X-Axis	236"/min		
Rapid Travers Z-Axis	236"/min		
Motor			
Servo Motor X-Axis	5.3 HP		
Servo Motor Z-Axis	8.0 HP		
Ball Screw			
X-Axis	Ø1.41", P6		
Z-Axis	Ø2.48", P12		
Tailstock			
Tailstock Quill (Nose, Taper, Bearing)	A-1-8, M.T. #6, 33024		
Tailstock Quill Diameter	Ø9.4"		
Tailstock Quill Travel	7.1"		
Dimensions			
Floor Space (L x W)	305" / 344" / 384" / 423" / 470" x 151"		
Machine Height	91"		
Weight			
Net Weight (lbs)	31,372 / 35,442 / 39,556 / 43,670 / 47,806		
Total Power Required			
100 KVA			